



MEDIPHACOS EE EMB 14 - Keraring Revisão 08 Página 1 de 9			
Elaboração: Maria Clara Almeida 	Revisão: Karine Lima 	Aprovação: Cláudia Azevedo 	Data de implementação: 21/12/2021

I. MOTIVO PARA REVISAO

Revisão	Histórico	Data de aprovação
08	Alteração da versão do item 200010006 IFU Keraring. Conforme proposta de alteração ID 324/2021. Não requer treinamento uma vez que a especificação de embalagem foi apenas atualizada.	20/12/2021
00	Emissão inicial.	19/12/2019

II. OBJETIVO

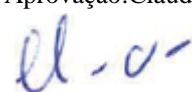
Fornecer as especificações das embalagens e rotulagens utilizadas nos modelos do produto anel corneano intraestromal Keraring (SI-5, SI-6, SG, AS-5, AS-6).

III. ESCOPO

Este documento se aplica aos setores de Qualidade e Limpeza de Implantes (QLI), Embalagem, Suprimentos, Logística e Gerência de Qualidade e Assuntos Regulatórios.

IV. ESPECIFICAÇÕES TÉCNICAS

4.1 Modelos e Especificações

4.1.1 Etiqueta embalagem primária:

4.1.1.1 Anel intraestromal simétrico

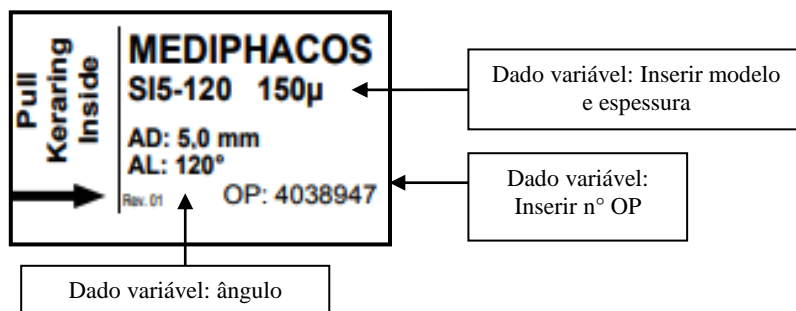

- **Layout:** 200050026 Etiqueta Estojo Universal Keraring Simétrico Rev 01
- **Dimensões:** 44,0 x 22,0 mm
- **Material:** Couche borracha
- **Disposição:** Afixada no estojo.

4.1.1.2 Anel intraestromal assimétrico

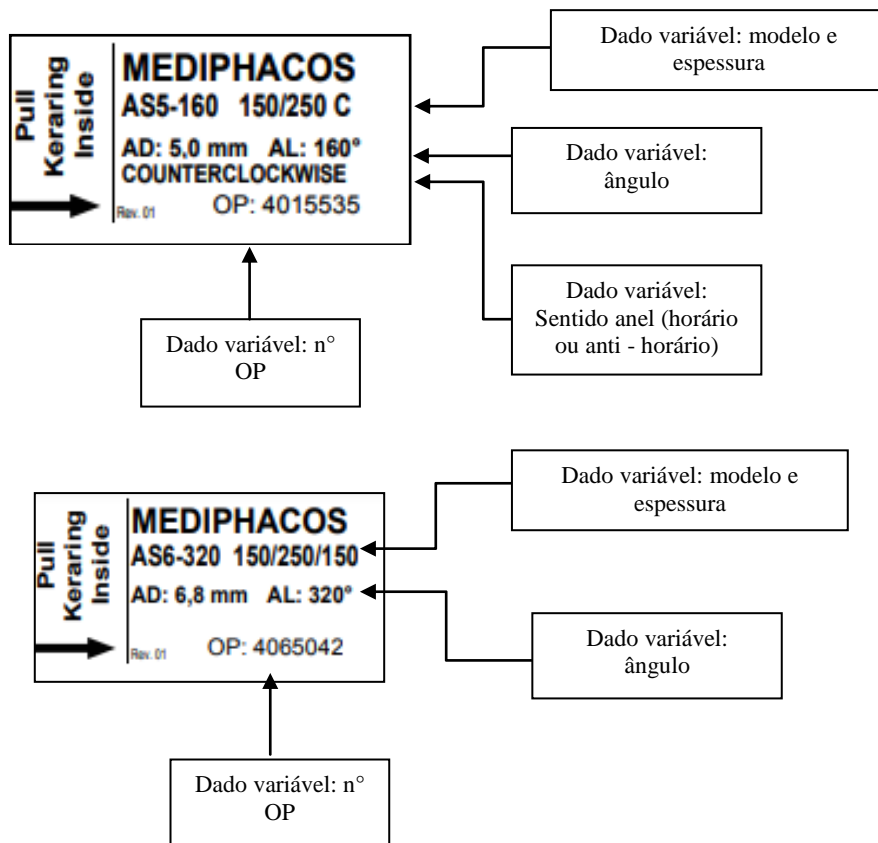

- **Layout:** 200050026 Etiqueta Estojo Universal Keraring Assimétrico Rev 01
- **Dimensões:** 44,0 x 22,0 mm
- **Material:** Couche borracha
- **Disposição:** Afixada no estojo.

4.1.1.3 Anel Intraestromal SG

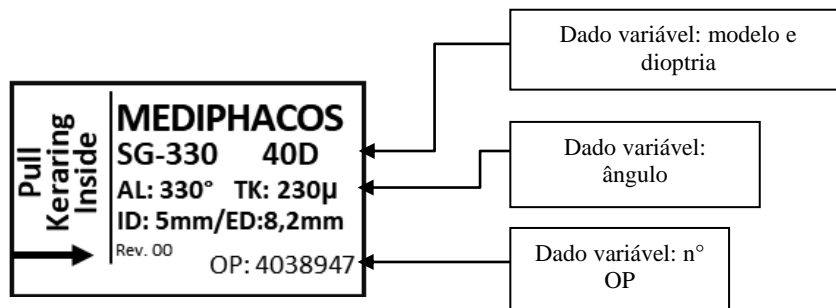

- **Layout:** 200050026 Etiqueta Estojo Universal Keraring SG Rev 00
- **Dimensões:** 44,0 x 22,0 mm
- **Material:** Couche borracha
- **Disposição:** Afixada no estojo.

4.1.2 Lacre de segurança de embalagem primária

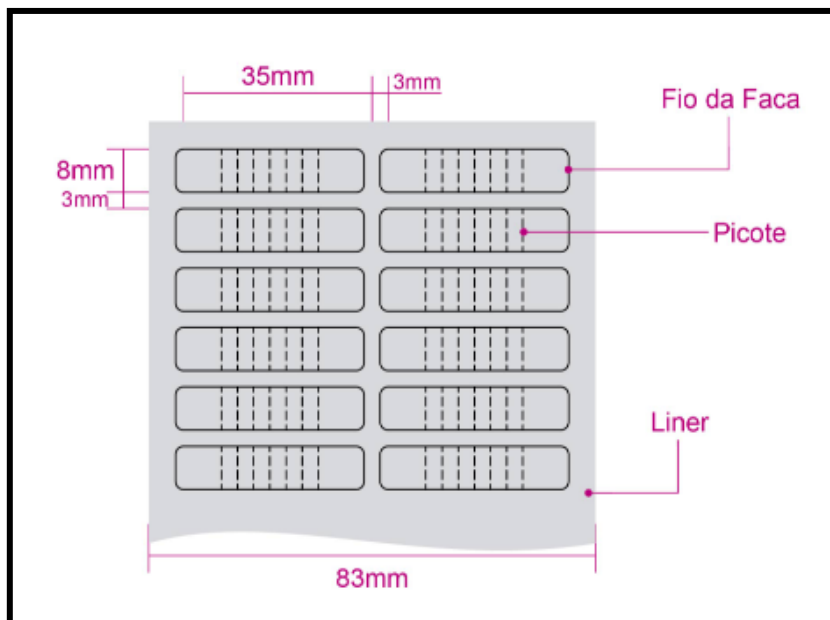

- **Layout:** 200030059 Etiquetas Lacre de Segurança para Estojos Rev 00
- **Dimensões:** 35,0 x 8,0 mm
- **Material:** Bopp Transparente
- **Adesivo:** Acrílico
- **Disposição:** Afixado na tampa e corpo do estojo, conforme DET IC 35.

4.1.3 Etiquetas embalagens secundária, final e do paciente:

4.1.3.1 Anel intraestromal simétrico

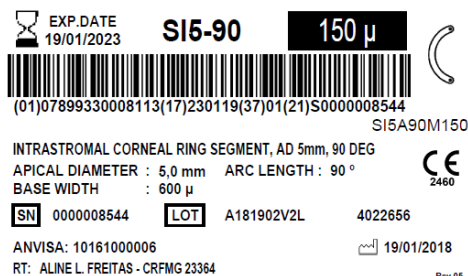

Etiqueta da embalagem final (afixadas no cartucho)

Dados variáveis:
- modelo, espessura e dimensões do anel;
- lote;
- número de série (SN);
- OP
- fabricação e validade.

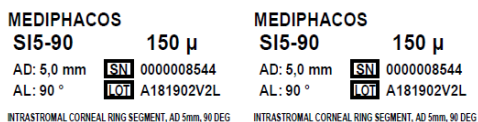

Etiquetas encaminhadas ao cliente (inseridas no cartucho)

Dados variáveis:
- modelo, espessura e dimensões do anel;
- lote;
- número de série.

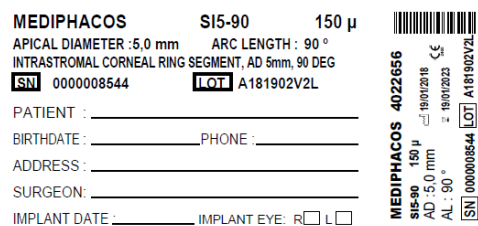
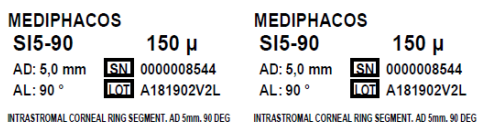
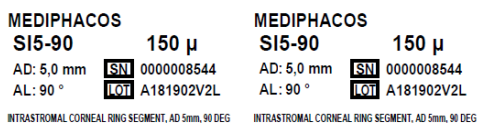
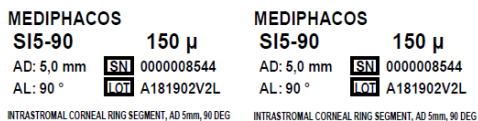

Etiqueta da embalagem secundária (afixadas no envelope)

Dados variáveis:
- modelo, espessura e dimensões do anel;
- lote;
- número de série;
- OP;
- data de fabricação e validade.

Etiqueta a ser afixada no cartão do paciente (inserida no cartucho)

Dados variáveis: modelo, espessura e dimensões do anel, lote e número de série.

- **Layout:** 200050003 Etiqueta Zebra Autofit
- **Descrição:** Etiquetas Keraring SI Rev 05
- **Dimensões:** 214,0 x 97,0 mm
- **Material:** adesivo resina
- **Disposição:** afixadas na embalagem final (cartucho), inseridas no cartucho, na embalagem secundária (envelope) e a ser afixada no cartão do paciente.

4.1.3.2 Anel intraestromal assimétrico

EXP. DATE 19/05/2022 **AS5-160** **150/250 C**



(01)07899330013889(17)220519(37)01(21)S0000003418
AS5160M15-25C

ASYM RING SEGMENT - COUNTERCLOCKWISE THICKNESS INCREASE 

APICAL DIAMETER : 5,0 mm ARC LENGTH : 160 °
BASE WIDTH : 600 µ 150 - 250 µ

SN 0000003418 **LOT** E171901V2L 4015535

ANVISA: 10161000006 19/05/2017
RT: ALINE L FREITAS - CRFMG 23364

Rev 04

Etiqueta da embalagem final (afixadas no cartucho)

Dados variáveis:

- modelo, espessura e dimensões do anel;
- lote;
- número de série (SN);
- OP;
- fabricação e validade.

<p>MEDIPHACOS AS5-160 150/250 C AD: 5,0 mm SN 0000003418 AL: 160 ° LOT E171901V2L COUNTERCLOCKWISE</p>	<p>MEDIPHACOS AS5-160 150/250 C AD: 5,0 mm SN 0000003418 AL: 160 ° LOT E171901V2L COUNTERCLOCKWISE</p>
<p>MEDIPHACOS AS5-160 150/250 C AD: 5,0 mm SN 0000003418 AL: 160 ° LOT E171901V2L COUNTERCLOCKWISE</p>	<p>MEDIPHACOS AS5-160 150/250 C AD: 5,0 mm SN 0000003418 AL: 160 ° LOT E171901V2L COUNTERCLOCKWISE</p>
<p>MEDIPHACOS AS5-160 150/250 C AD: 5,0 mm SN 0000003418 AL: 160 ° LOT E171901V2L COUNTERCLOCKWISE</p>	<p>MEDIPHACOS AS5-160 150/250 C AD: 5,0 mm SN 0000003418 AL: 160 ° LOT E171901V2L COUNTERCLOCKWISE</p>
<p>MEDIPHACOS AS5-160 150/250 C AD: 5,0 mm SN 0000003418 AL: 160 ° LOT E171901V2L COUNTERCLOCKWISE</p>	<p>MEDIPHACOS AS5-160 150/250 C AD: 5,0 mm SN 0000003418 AL: 160 ° LOT E171901V2L COUNTERCLOCKWISE</p>

Etiquetas encaminhadas ao cliente (inseridas no cartucho)

Dados variáveis:

- modelo, espessura e dimensões do anel;
- lote;
- número de série.

MEDIPHACOS AS5-160 150/250 C

APICAL DIAMETER : 5,0 mm ARC LENGTH : 160 °
ASYM RING SEGMENT - COUNTERCLOCKWISE THICKNESS INCREASE

SN 0000003418 **LOT** E171901V2L

PATIENT : _____
BIRTHDATE : _____PHONE : _____
ADDRESS : _____
SURGEON : _____
IMPLANT DATE : _____ IMPLANT EYE: R L

MEDIPHACOS 4015535
AS5-160 150/250 C 19/05/2017
AD : 5,0 mm 19/05/2022
AL : 160 °
SN 0000003418 **LOT** E171901V2L





Etiqueta da embalagem secundária (afixadas no envelope)

Dados variáveis:

- modelo, espessura e dimensões do anel;
- lote;
- número de série;
- OP;
- data de fabricação e validade.

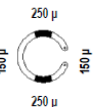
Etiqueta a ser afixada no cartão do paciente

Dados variáveis: modelo, espessura e dimensões do anel, lote e número de série.

 EXP. DATE 19/10/2025 **AS5-320 150/250/150**  250 µ
 (01)07899330199569(17)251019(30)01(21)S0000000244 AS5320M152515
 INTRASTROMAL CORNEAL RING - SINUSOIDAL THICKNESS PROGRESSION
 APICAL DIAMETER : 5,7 mm ARC LENGTH : 320 ° 
 BASE WIDTH : 700 µ 150 - 250 - 150 µ 2460
SN 0000000244 **LOT** J201901V2L 4057526
 ANVISA: 10161000006  19/10/2020
 RT: ALINE L. FREITAS - CRFMG 23364 Rev 04

Etiqueta da embalagem final (afixadas no cartucho)

Dados variáveis:
 - modelo, variação de espessura e dimensões do anel;
 - lote;
 - número de série (SN);
 - OP;
 - fabricação e validade.

MEDIPHACOS
AS5-320 150/250/150
 AD: 5,7 mm **SN** 0000000244
 AL: 320 ° **LOT** J201901V2L

MEDIPHACOS
AS5-320 150/250/150
 AD: 5,7 mm **SN** 0000000244
 AL: 320 ° **LOT** J201901V2L

MEDIPHACOS
AS5-320 150/250/150
 AD: 5,7 mm **SN** 0000000244
 AL: 320 ° **LOT** J201901V2L

MEDIPHACOS
AS5-320 150/250/150
 AD: 5,7 mm **SN** 0000000244
 AL: 320 ° **LOT** J201901V2L

MEDIPHACOS
AS5-320 150/250/150
 AD: 5,7 mm **SN** 0000000244
 AL: 320 ° **LOT** J201901V2L

MEDIPHACOS
AS5-320 150/250/150
 AD: 5,7 mm **SN** 0000000244
 AL: 320 ° **LOT** J201901V2L

MEDIPHACOS
AS5-320 150/250/150
 AD: 5,7 mm **SN** 0000000244
 AL: 320 ° **LOT** J201901V2L

MEDIPHACOS
AS5-320 150/250/150
 AD: 5,7 mm **SN** 0000000244
 AL: 320 ° **LOT** J201901V2L

Etiquetas encaminhadas ao cliente (inseridas no cartucho)

Dados variáveis:
 - modelo, variação da espessura e dimensões do anel;
 - lote;
 - número de série.

MEDIPHACOS AS5-320 150/250/150
 APICAL DIAMETER : 5,7 mm ARC LENGTH : 320 °
 INTRASTROMAL CORNEAL RING - SINUSOIDAL THICKNESS PROGRES: 
SN 0000000244 **LOT** J201901V2L
 PATIENT : _____
 BIRTHDATE : _____ PHONE : _____
 ADDRESS : _____
 SURGEON : _____
 IMPLANT DATE : _____ IMPLANT EYE: R L

MEDIPHACOS 4057526
AS5-320 150/250/150
AD: 5,7 mm
AL: 320 °
 19/10/2020

Etiqueta da embalagem secundária (afixadas no envelope)

Dados variáveis:
 - modelo, variação da espessura e dimensões do anel;
 - lote;
 - número de série;
 - OP
 - data de fabricação e validade.

Etiqueta a ser afixada no cartão do paciente

Dados variáveis: modelo, variação da espessura e dimensões do anel, lote e número de série.

- **Layout:** 200050003 Etiqueta Zebra Autofit
- **Descrição:** Etiquetas Keraring AS Rev 04
- **Dimensões:** 214,0 x 97,0 mm
- **Material:** adesivo resina
- **Disposição:** afixadas na embalagem final (cartucho), inseridas no cartucho, na embalagem secundária (envelope) e a ser afixada no cartão do paciente.

4.1.3.3 Anel intraestromal SG



EXP. DATE
21/07/2027

SG-330 35,0 D

(01)07899330091443(17)270802(30)01(21)S0000000004

SGA330D35M300

INTRASTROMAL CORNEAL RING SEGMENT SG-330 DEG

INTERNAL DIAMETER: 4,7 mm ARC LENGTH: 330°

THICKNESS: 300 µ BASE WIDTH: 1750 µ

CE 2460

SN 000000004 LOT G222107V2L 4075424

ANVISA: 10161000006 21/07/2022

RT: ALINE L. FREITAS - CRFMG 23364

Rev 00

Etiqueta da embalagem final (afixadas no cartucho)

Dados variáveis:

- modelo, dioptria e dimensões do anel;
- lote;
- número de série (SN);
- OP;
- fabricação e validade.



MEDIPHACOS SG-330 35,0 D

ID : 4,7 mm SN 0000000004

AL: 330° LOT G222107V2L

INTRASTROMAL CORNEAL RING SEGMENT SG-330 DEG

MEDIPHACOS SG-330 35,0 D

ID : 4,7 mm SN 0000000004

AL: 330° LOT G222107V2L

INTRASTROMAL CORNEAL RING SEGMENT SG-330 DEG

MEDIPHACOS SG-330 35,0 D

ID : 4,7 mm SN 0000000004

AL: 330° LOT G222107V2L

INTRASTROMAL CORNEAL RING SEGMENT SG-330 DEG

MEDIPHACOS SG-330 35,0 D

ID : 4,7 mm SN 0000000004

AL: 330° LOT G222107V2L

INTRASTROMAL CORNEAL RING SEGMENT SG-330 DEG

Etiquetas encaminhadas ao cliente (inseridas no cartucho)

Dados variáveis:

- modelo, dioptria e dimensões do anel;
- lote;
- número de série.

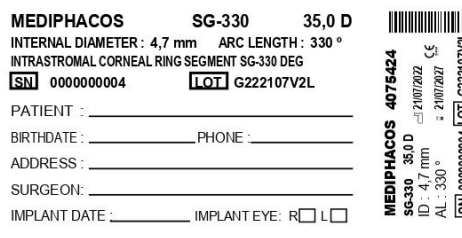

MEDIPHACOS SG-330 35,0 D

INTERNAL DIAMETER: 4,7 mm ARC LENGTH: 330°

INTRASTROMAL CORNEAL RING SEGMENT SG-330 DEG

SN 0000000004 LOT G222107V2L

PATIENT : _____

BIRTHDATE : _____ PHONE : _____

ADDRESS : _____

SURGEON : _____

IMPLANT DATE : _____ IMPLANT EYE: R L

MEDIPHACOS 4075424

SG-330 35,0 D

ID : 4,7 mm SN 0000000004

AL : 330° LOT G222107V2L

Etiqueta da embalagem secundária (afixadas no envelope)

Dados variáveis:

- modelo, dioptria e dimensões do anel;
- lote;
- número de série;
- OP;
- data de fabricação e validade.

Etiqueta a ser afixada no cartão do paciente

Dados variáveis: modelo, dioptria e dimensões do anel, lote e número de série.

- **Layout:** 200050003 Etiqueta Zebra Autofit
- **Descrição:** Etiquetas Keraring SG Rev 00
- **Dimensões:** 214,0 x 97,0 mm
- **Material:** adesivo resina
- **Disposição:** afixadas na embalagem final (cartucho), inseridas no cartucho, na embalagem secundária (envelope) e a ser afixada no cartão do paciente.

4.1.4 Cartão do paciente:



- **Layout:** 200050012 Cartão Paciente Keraring Rev 04
- **Dimensões:** 80 x 95 mm
- **Material:** tinta preta em cartão vitabianco, 325 g.
- **Laminação:** brilho
- **Disposição:** inserido no cartucho
- **Pantones:** 8062 C, 7633 C e Black C

4.1.5 Cartucho:



- Faca
- Pantone 8062 C
- PANTONE 7633 C
- Pantone BLACK C

- **Layout:** 200020004 Cartucho Keraring Rev 06
- **Dimensões (fechado):** 96 x 26 x 145 mm
- **Dimensões (aberto):** 25,5 x 24,0 cm
- **Material:** tinta preta em cartão vitabianco, 325 g
- **Cores:** 3 x 0
- **Laminação:** brilho.
- **Pantones:** 8062 C, 7633 C e Black C

4.1.6 Instrução de uso:

- **Layout:** 200010006 IFU Keraring Rev 10
- **Disposição:** inserida no cartucho

V. ANEXOS

Anexo I - EE EMB 14 Keraring (English version)

VI. REFERÊNCIAS

ABNT NBR ISO 13485/2016 - Itens: 4.2.1; 4.2.4 e 4.2.5.

ABNT NBR ISO 15223.1:2015



ANVISA RDC 16/2013 - Item: 5.2.

IPA GQA 08 - Controle de Embalagem e Material de Marketing

IPP EMB 03 - Alocação e Impressão de Etiquetas

DET IC 35 - Lacre de Segurança Estojo Keraring

Anexo I – EE EMB 14 Keraring (English version)

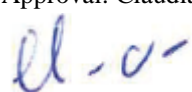
MEDIPHACOS EE EMB 14 - Keraring Revisão 08 Page 1 of 10			
Elaboration: Maria Clara Almeida 	Review: Karine Lima 	Approval: Cláudia Azevedo 	Implementation Date: Dec 21, 2021

I. REASON FOR REVIEW

Review	Historic	Approval Date
08	Changed the version of item 200010006 IFU Keraring. According to the proposed amendment ID 324/2021. No training required as the packaging specification has just been updated.	Dec 20, 2021
00	Initial issue.	Jan 08, 2019

II. GOAL

Provide the specifications of the packaging and labeling used in the models of the Keraring intrastromal corneal ring product (SI-5, SI-6, SG, AS-5, AS-6) under the scope of the CE marking.

III. SCOPE

This document applies to the Quality and Cleaning of Implants, Packaging, Supplies, Logistics and Quality Management and Regulatory Affairs sectors.

IV. TECHNICAL SPECIFICATIONS

4.1. Models and Specifications

4.1.1. Primary packaging label:

4.1.1.1 Symmetrical intrastromal ring

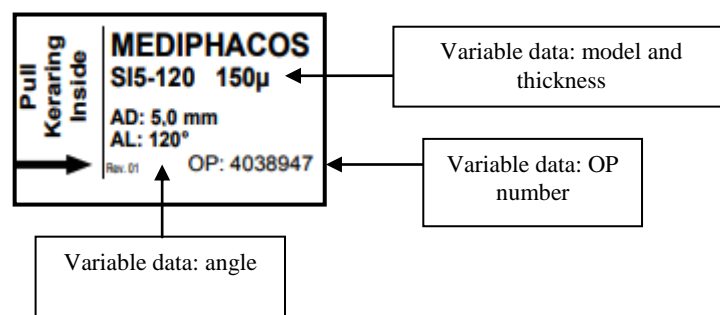

- **Layout:** 200050026 Symmetrical Universal Keraring Case Label Rev 01
- **Dimensions:** 44,0 x 22,0 mm
- **Material:** Rubber couche
- **Disposition:** Affixed to the case.

4.1.1.2 Asymmetrical intrastromal ring

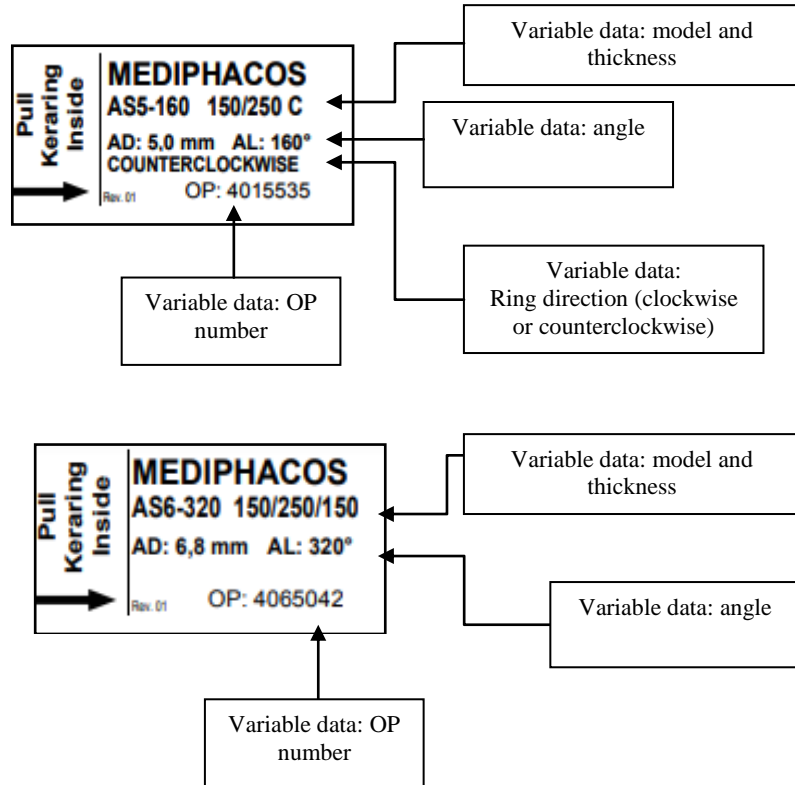

- **Layout:** 200050026 Asymmetric Universal Keraring Case Label Rev 01
- **Dimensions:** 44,0 x 22,0 mm
- **Material:** Rubber couche
- **Disposition:** Affixed to the case.

4.1.1.3 SG Intrastromal ring

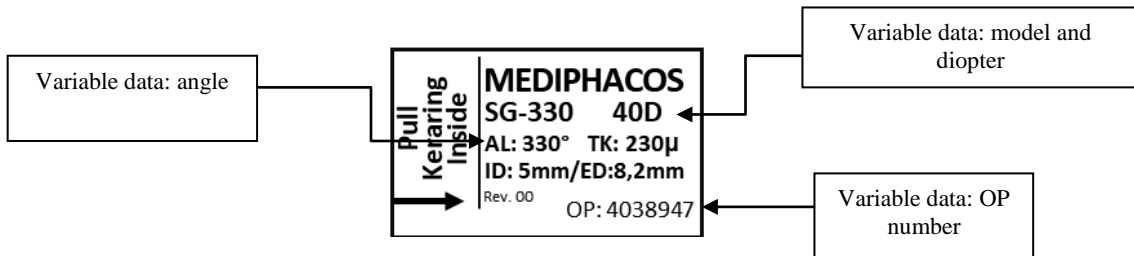

- **Layout:** 200050026 Universal Keraring SG Case Label Rev 00
- **Dimensions:** 44,0 x 22,0 mm
- **Material:** Rubber couche
- **Disposition:** Affixed to the case.

4.1.2. Primary packaging security seal

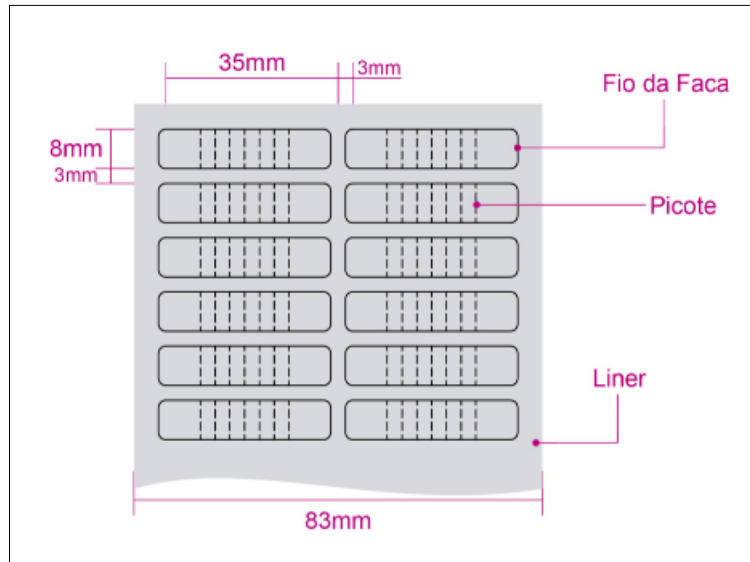

- **Layout:** 200030059 Security Seal Labels for Cases Rev 00
- **Dimension:** 35,0 x 8,0 mm
- **Material:** Clear Bopp
- **Adesivo:** Acrílico
- **Disposição:** Affixed to the cover and case body, as DET IC 35.

4.1.3. Secondary, final and patient packaging labels:

4.1.3.1 Symmetrical intrastromal ring

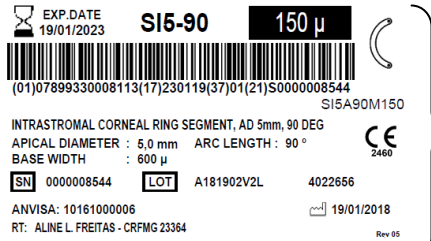

Final packaging label (affixed to the cartridge)
 Variable data:
 - model, thickness and dimensions of the ring;
 - batch;
 - serial number (SN);
 - OP
 - manufacture and validity.

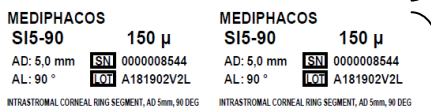

Labels sent to the customer (inserted in the cartridge)
 Variable data:
 - model, thickness and dimensions of the ring;
 - batch;
 - serial number.

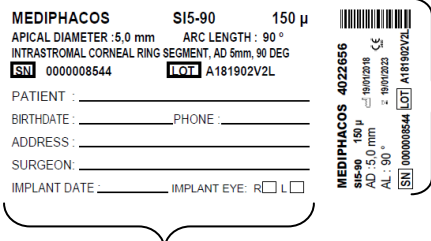



Secondary packaging label (affixed to the envelope)
 Variable data:
 - model, thickness and dimensions of the ring;
 - batch;
 - serial number;
 - OP
 - date of manufacture and validity.

Label to be affixed to the patient's card (inserted in the cartridge)
 Variable data: model, thickness and dimensions of the ring, batch and serial number.

- **Layout:** 200050003Etiqueta Zebra Autofit
- **Description:** Keraring SI labels Rev 05
- **Dimensions:** 214,0 x 97,0 mm
- **Material:** resin adhesive
- **Disposition:** affixed to the final packaging (cartridge), inserted into the cartridge, the secondary packaging (envelope) and to be affixed to the patient's card.

4.1.3.2 Asymmetrical intrastromal ring

 EXP. DATE
 19/05/2022 **AS5-160** **150/250 C** 



 (01)07899330013889(17)220519(37)01(21)S0000003418 AS5160M15-25C

ASYM RING SEGMENT - COUNTERCLOCKWISE THICKNESS INCREASE 
 APICAL DIAMETER : 5,0 mm ARC LENGTH : 160 °
 BASE WIDTH : 600 µ 150 - 250 µ
SN 0000003418 **LOT** E171901V2L 4015535
 ANVISA: 10161000006 19/05/2017
 RT: ALINE L. FREITAS - CRFMG 23364 Rev 04

Final packaging label (affixed to the cartridge)
 Variable data:
 - model, thickness and dimensions of the ring;
 - batch;
 - serial number (SN);
 - OP;
 - manufacture and validity.

<p>MEDIPHACOS AS5-160 150/250 C AD: 5,0 mm SN 0000003418 AL: 160 ° LOT E171901V2L <small>COUNTERCLOCKWISE</small></p>	<p>MEDIPHACOS AS5-160 150/250 C AD: 5,0 mm SN 0000003418 AL: 160 ° LOT E171901V2L <small>COUNTERCLOCKWISE</small></p>
<p>MEDIPHACOS AS5-160 150/250 C AD: 5,0 mm SN 0000003418 AL: 160 ° LOT E171901V2L <small>COUNTERCLOCKWISE</small></p>	<p>MEDIPHACOS AS5-160 150/250 C AD: 5,0 mm SN 0000003418 AL: 160 ° LOT E171901V2L <small>COUNTERCLOCKWISE</small></p>
<p>MEDIPHACOS AS5-160 150/250 C AD: 5,0 mm SN 0000003418 AL: 160 ° LOT E171901V2L <small>COUNTERCLOCKWISE</small></p>	<p>MEDIPHACOS AS5-160 150/250 C AD: 5,0 mm SN 0000003418 AL: 160 ° LOT E171901V2L <small>COUNTERCLOCKWISE</small></p>
<p>MEDIPHACOS AS5-160 150/250 C AD: 5,0 mm SN 0000003418 AL: 160 ° LOT E171901V2L <small>COUNTERCLOCKWISE</small></p>	<p>MEDIPHACOS AS5-160 150/250 C AD: 5,0 mm SN 0000003418 AL: 160 ° LOT E171901V2L <small>COUNTERCLOCKWISE</small></p>

Labels sent to the customer (inserted in the cartridge)
 Variable data:
 - model, thickness and dimensions of the ring;
 - batch;
 - serial number.

MEDIPHACOS AS5-160 150/250 C 
 APICAL DIAMETER : 5,0 mm ARC LENGTH : 160 °
 ASYM RING SEGMENT - COUNTERCLOCKWISE THICKNESS INCREASE 
SN 0000003418 **LOT** E171901V2L





PATIENT : _____
 BIRTHDATE : _____ PHONE : _____
 ADDRESS : _____
 SURGEON : _____
 IMPLANT DATE : _____ IMPLANT EYE: R L

MEDIPHACOS 4015535
 AS5-160 150/250 C 19/05/2017
 AD: 5,0 mm 19/05/2022
 AL: 160 °
SN 0000003418 **LOT** E171901V2L

Secondary packaging label (affixed to the envelope)
 Variable data:
 - model, thickness and dimensions of the ring;
 - batch;
 - serial number;
 - OP;
 - date of manufacture and validity.

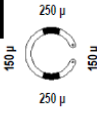
Label to be affixed to the patient's card (inserted in the cartridge)
 Variable data: model, thickness and dimensions of the ring, batch and serial number.

MEDIPHACOS
 EE EMB 14 - Keraring
 Review 08
 Page 6 of 10

 EXP. DATE
 19/10/2025 **AS5-320 150/250/150** 

 (01)07899330199569(17)251019(30)01(21)S0000000244 AS5320M152515
 INTRASTROMAL CORNEAL RING - SINUSOIDAL THICKNESS PROGRESSION
 APICAL DIAMETER : 5,7 mm ARC LENGTH : 320 ° 
 BASE WIDTH : 700 μ 150 - 250 - 150 μ 2460
SN 0000000244 **LOT** J201901V2L 4057526
 ANVISA: 10161000006  19/10/2020
 RT: ALINE L. FREITAS - CRFMG 23364 Rev 04

Final packaging label (attached to cartridge)
 Variable data:
 - model, thickness variation and dimensions of the ring;
 - batch;
 - serial number (SN);
 - OP;
 - manufacture and validity.

<p>MEDIPHACOS AS5-320 150/250/150 AD: 5,7 mm SN 0000000244 AL: 320 ° LOT J201901V2L</p>	<p>MEDIPHACOS AS5-320 150/250/150 AD: 5,7 mm SN 0000000244 AL: 320 ° LOT J201901V2L</p>
--	--

<p>MEDIPHACOS AS5-320 150/250/150 AD: 5,7 mm SN 0000000244 AL: 320 ° LOT J201901V2L</p>	<p>MEDIPHACOS AS5-320 150/250/150 AD: 5,7 mm SN 0000000244 AL: 320 ° LOT J201901V2L</p>
--	--

<p>MEDIPHACOS AS5-320 150/250/150 AD: 5,7 mm SN 0000000244 AL: 320 ° LOT J201901V2L</p>	<p>MEDIPHACOS AS5-320 150/250/150 AD: 5,7 mm SN 0000000244 AL: 320 ° LOT J201901V2L</p>
--	--

<p>MEDIPHACOS AS5-320 150/250/150 AD: 5,7 mm SN 0000000244 AL: 320 ° LOT J201901V2L</p>	<p>MEDIPHACOS AS5-320 150/250/150 AD: 5,7 mm SN 0000000244 AL: 320 ° LOT J201901V2L</p>
--	--

Labels sent to the customer (inserted in the cartridge)
 Variable data:
 - model, variation of the thickness and dimensions of the ring;
 - batch;
 - serial number.

MEDIPHACOS AS5-320 150/250/150
 APICAL DIAMETER :5,7 mm ARC LENGTH : 320 °
 INTRASTROMAL CORNEAL RING - SINUSOIDAL THICKNESS PROGRES:
SN 0000000244 **LOT** J201901V2L 
 PATIENT : _____
 BIRTHDATE : _____ PHONE : _____
 ADDRESS : _____
 SURGEON: _____
 IMPLANT DATE : _____ IMPLANT EYE: R L

MEDIPHACOS 4057526
 AS5-320 150/250/150
 AD : 5,7 mm
 AL : 320 °
 19/10/2020
 19/10/2025

Secondary packaging label (attached to the envelope)
 Variable data:
 - model, variation of the thickness and dimensions of the ring;
 - batch;
 - serial number;
 - OP
 - date of manufacture and expiration date.

Label to be affixed to the patient's card

Variable data: model, variation of ring thickness and dimensions. lot and serial number.

- **Layout:** 200050003 Etiqueta Zebra Autofit
- **Description:** Keraring AS labels Rev 04
- **Dimensions:** 214,0 x 97,0 mm
- **Material:** resin adhesive
- **Disposition:** affixed to the final packaging (cartridge), inserted into the cartridge, the secondary packaging (envelope) and to be affixed to the patient's card.

4.1.3.3 Intrastromal ring SG



Final packaging label (affixed to the cartridge)
 Variable data:
 - model, diopter and dimensions of the ring;
 - batch;
 - serial number (SN);
 - OP;
 - manufacture and validity.

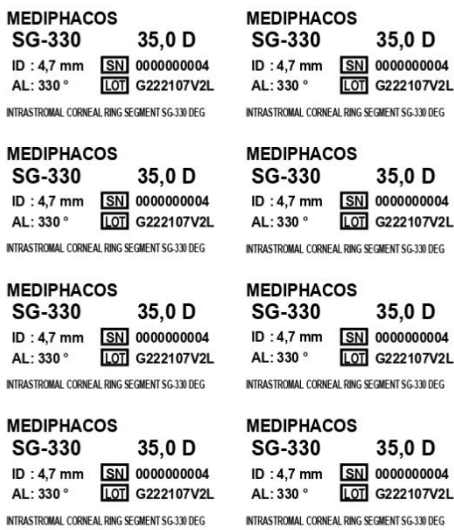

Labels sent to the customer (inserted in the cartridge)
 Variable data:
 - model diopter and dimensions of the ring;
 - batch;
 - serial number.

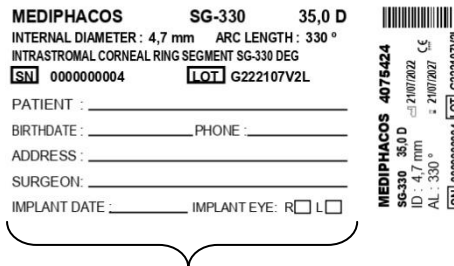

Secondary packaging label (affixed to the envelope)
 Variable data:
 - model, diopter and dimensions of the ring;
 - batch;
 - serial number;
 - OP;
 - date of manufacture and validity.

Label to be affixed to the patient's card (inserted in the cartridge)
 Variable data: model, diopter and dimensions of the ring, batch and serial number.

- **Layout:** 200050003 Etiqueta Zebra Autofit
- **Description:** Keraring SG Labels Rev 00
- **Dimensions:** 214,0 x 97,0 mm
- **Material:** resin adhesive
- **Disposition:** affixed to the final packaging (cartridge), inserted into the cartridge, the secondary packaging (envelope) and to be affixed to the patient's card.

4.1.4. Patient card:



- **Layout:** 200050012 Keraring Patient Card Rev 04
- **Dimensions:** 80 x 95 mm
- **Material:** black ink on vitabianco card, 325 g.
- **Lamination:** shine
- **Disposition:** inserted in the cartridge
- **Pantones:** 8062 C, 7633 C and Black C

4.1.5. Cartridge:



- **Layout:** 200020004 Keraring Cartridge Rev 06
- **Dimensions (closed):** 96 x 26 x 145 mm
- **Dimensions (open):** 25,5 x 24,0 cm
- **Material:** black ink on vitabianco card, 325 g
- **Colors:** 3 x 0
- **Lamination:** shine.
- **Pantones:** 8062 C, 7633 C and Black C

4.1.6. Instruction for use:

- **Layout:** 200010006 IFU Keraring Rev 10
- **Disposition:** inserted in the cartridge

V. ANNEXES

Not applicable.

VI. REFERENCES

ABNT NBR ISO 13485/2016 - Itens: 4.2.1; 4.2.4 e 4.2.5.
ABNT NBR ISO 15223.1:2015
ANVISA RDC 16/2013 - Item: 5.2.
IPA GQA 08 - Control of Packaging and Marketing Material
IPP EMB 03 - Label Allocation and Printing
DET IC 35 - Security Seal Labels for Cases Keraring